

Paul Ocholla - National Grid, Grain LNG
International LNG Congress, 14-15 March 2016



Agenda

- Grain LNG
- LNG - The Product
- LNG Transition Dynamics
 - UK Market
 - LNG Off-Grid
 - LNG HGV Fuel
- Grain LNG Truck Loading Facility



Our Terminal & Shippers

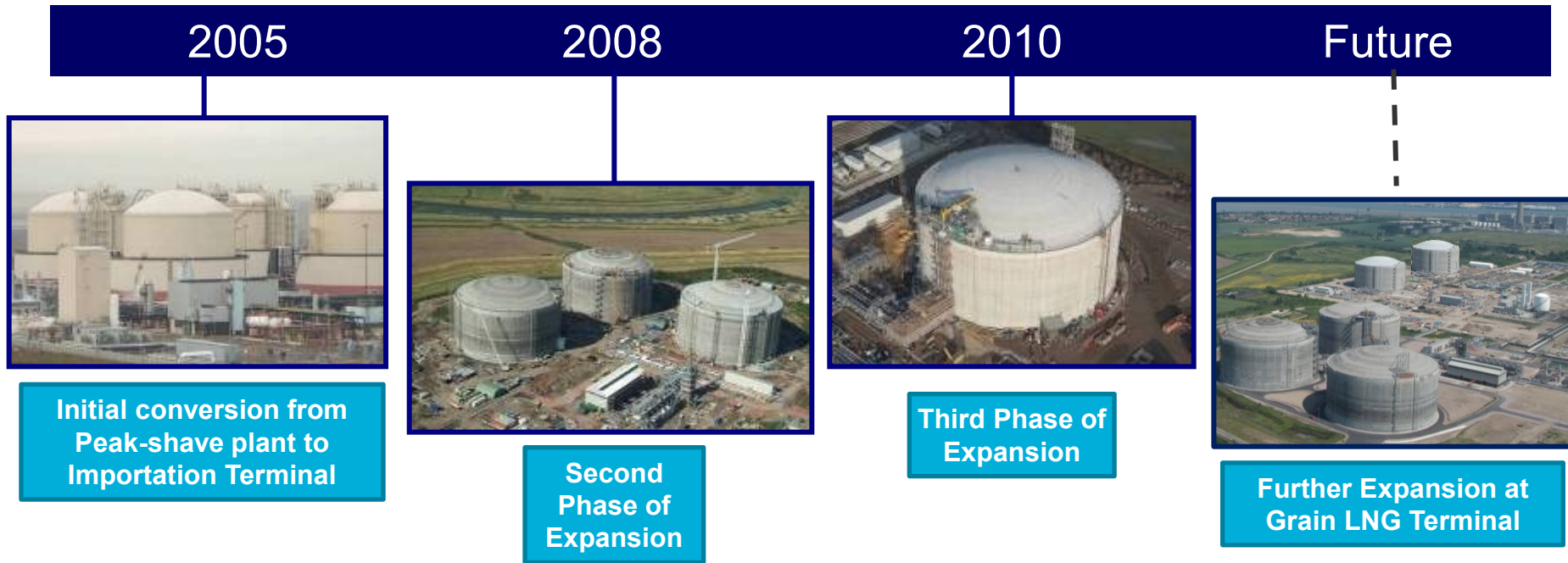











- 30 years of LNG experience
- Management of 1,000,000m3 storage space
- 2 purpose built jetties with Qmax capability
- Flexible & reliable services to customer and market needs

The Product - Liquefied Natural Gas (LNG)

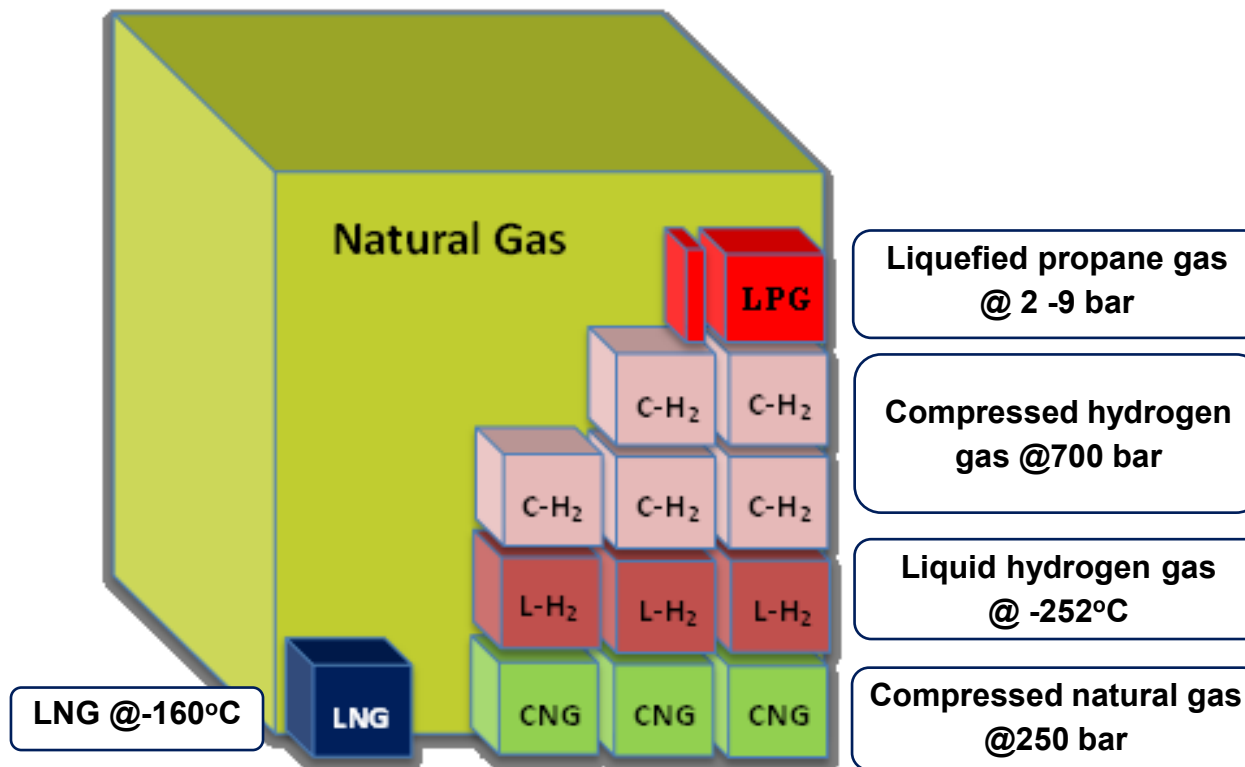
- There is an abundant and secure global supply of natural gas
- LNG is more energy dense; requires refuelling less often
- LNG is more competitive, safer and reliable



Transition from Traditional Fuels

- Up to 15% CO2 savings per annum per truck
- Significant reduction in NOx, SOx & Particulates emissions
- Worldwide expansion of Emissions Control Areas for 2020

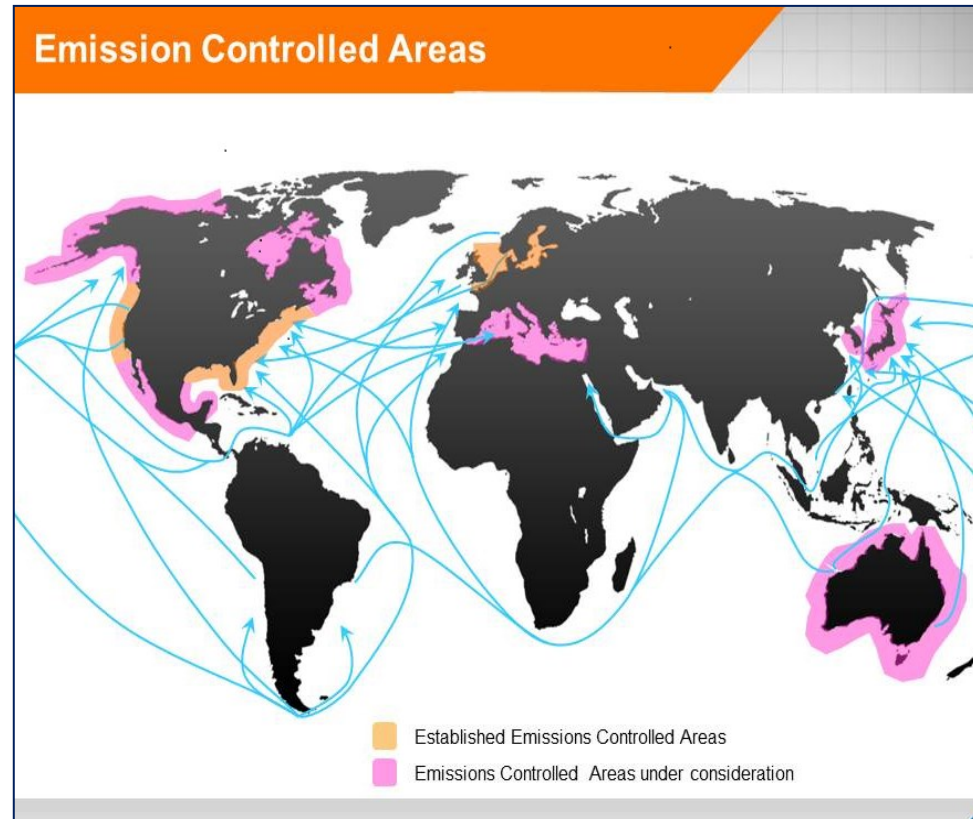
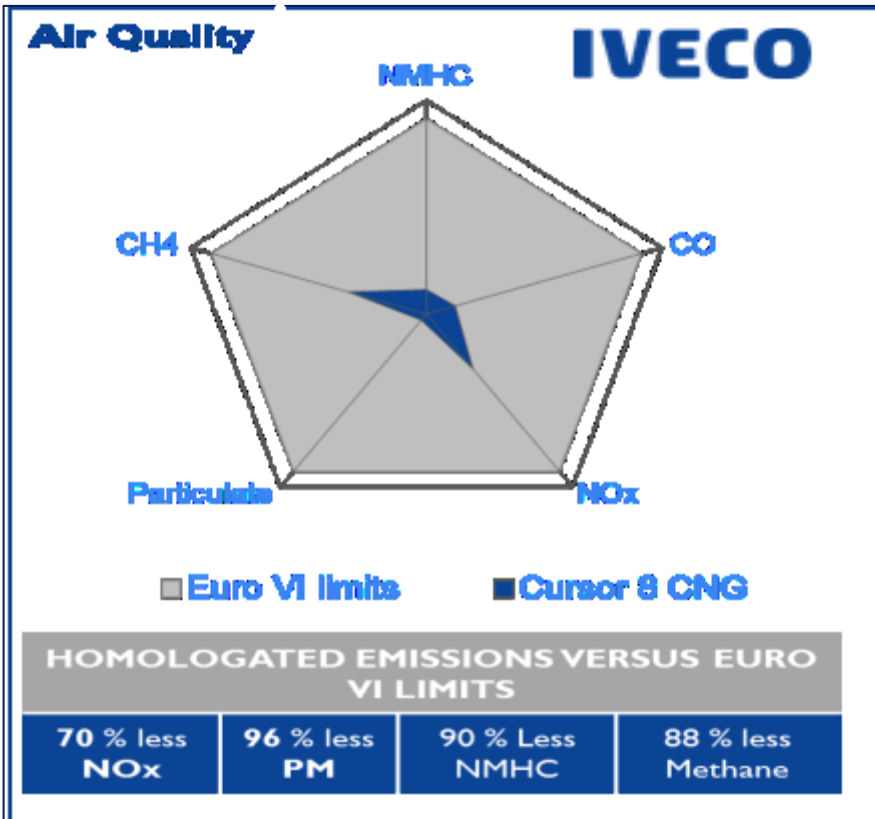

The UK Market

- ~150,000tpa forecast for 2020 versus ~26,000 tpa (2016)
- Baseline demand from off-grid I&C ~100,000 tpa (2020)
- Growth from other market sectors to accelerate from 2018



Off-grid industrial & commercial



Road fuel



Power generation



Marine bunkering

LNG Case for Off-Grid Use

- Up to 20% / 50% CO₂ savings per LPG / HFO conversion
- Up to 40% delivery and operation cost savings
- Future proofs business ready for pipeline gas connection

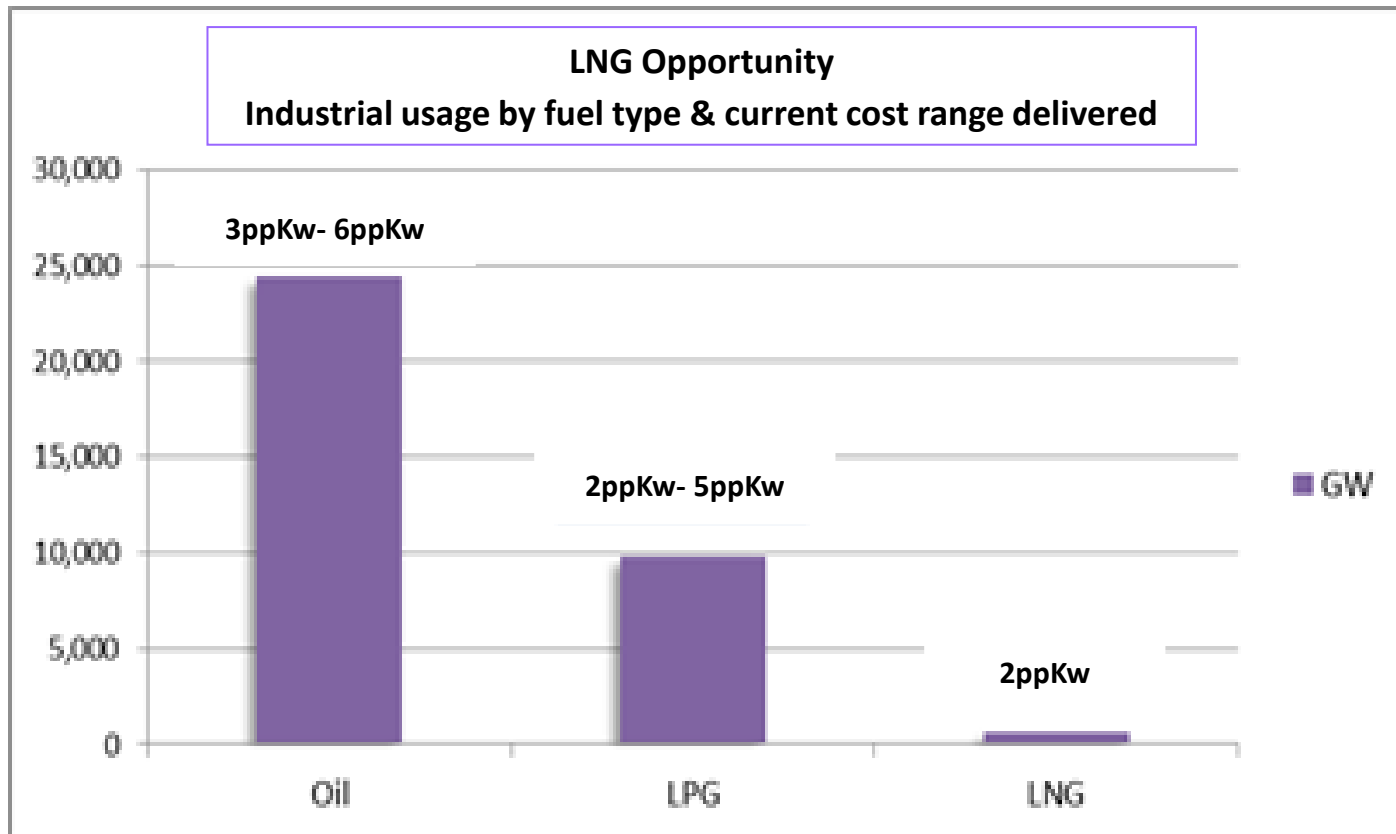

LNG Case for HGVs Fuel

- EU Directive to rollout sufficient LNG & CNG stations by 2025
- 10 year fuel duty differential in place until 2024
- Total cost of ownership 7% cheaper than Euro 6 Diesel¹

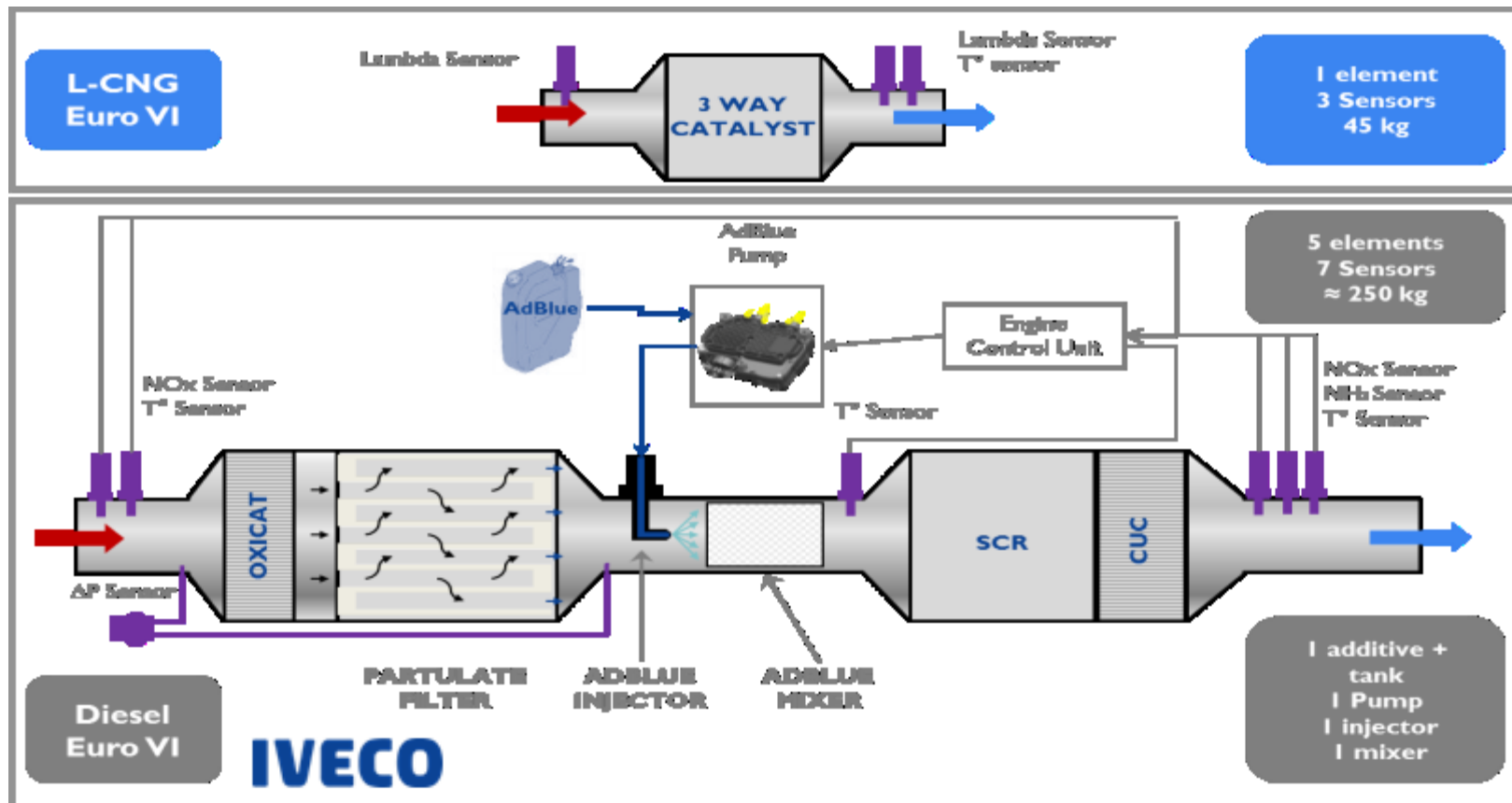

¹Iveco – NGV Day Oct 2015

The Grain LNG Truck Loading Facility

- 24/7, multi-bay facility offering 36 slots day
- Competitive & flexible commercial terms
- Excellent reliability and safety record

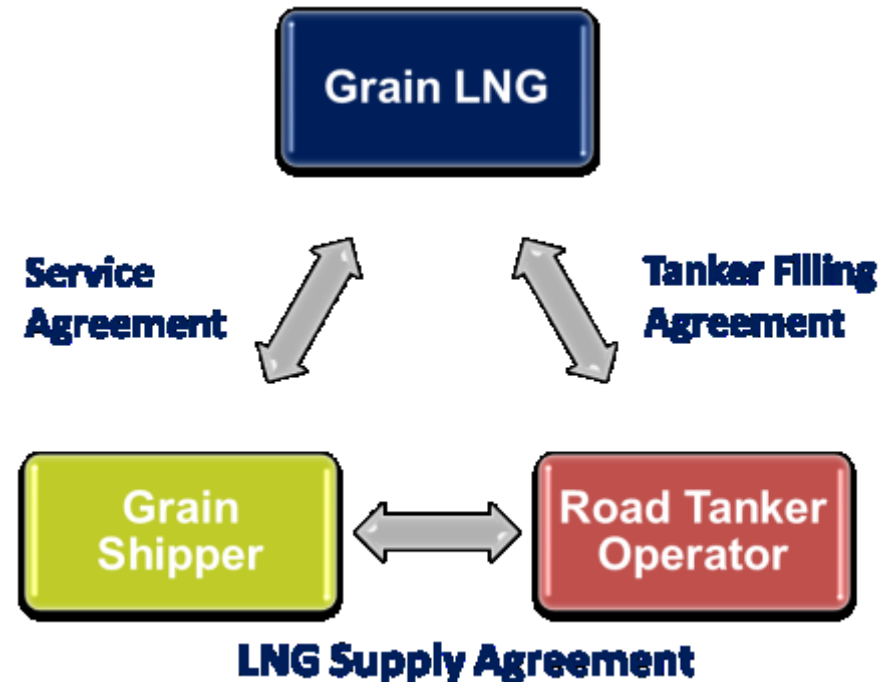

Questions?

- Thanks for your attention

Contact Details:

Paul Ocholla

Email: Paul.Ocholla@nationalgrid.com

Telephone: 0044 (0) 1634 273173